

LTS[®]

Humidification system product catalog



Liquid-to-steam.

DRI STEEM[®]
HUMIDIFIER COMPANY



Use existing hot water with LTS[®]

Humidify using an existing energy source

LTS: liquid to steam. For buildings with an existing 240°F hot liquid source, DRI-STEEM's unique LTS system can be a very economical way to create steam for humidification. The LTS takes energy from an existing hot liquid source (typically hot water), and transfers that energy through a heat exchanger to makeup water in the LTS evaporating chamber. This heat exchange process generates chemical-free steam for humidification from the regularly-replenished supply of makeup water.

Several performance, steam and capacity options

Given a hot liquid source, the LTS can be used in a variety of building environments. Because the LTS can use any type of makeup water: tap, softened, reverse osmosis, or deionized, it provides several steam quality options, achieving the highest performance and cleanest steam when using demineralized makeup water.

The LTS also has four available dispersion options, allowing it to accommodate a wide range of absorption requirements.

Further enhancing its application flexibility, the LTS has a very broad capacity range: from 9 to 540 lbs/hr for a single unit, up to 2160 lbs/hr with four units linked together.

Quality construction from the industry leader

For more than 30 years, DRI-STEEM has been leading the industry with creative and reliable humidification solutions. Our focus on quality is evident in the construction of the LTS, which features cleanable, stainless steel construction, and an industry-leading two year warranty that covers all parts. More LTS features are described on the following pages.

The LTS is commonly used in manufacturing facilities requiring controlled relative humidity levels.



LTS[®] features.

You're buying a system not just a humidifier

Creating humidity with the LTS is a three-step process:

1. Create steam.

The LTS humidifier unit uses a heat exchanger to boil water to create steam.

2. Control.

A microprocessor-based controller monitors and controls the creation and dispersion of steam.

3. Disperse.

Dispersion units disperse steam into the air.

The components of this three-step process work together as an engineered system, configured for each particular application.

Features and benefits of the LTS system are highlighted on this page, and described in more detail on the following pages.

Reliable performance

- Control to $\pm 5\%$ RH
- Electronically monitored water level ensures safe and reliable operation
- Diagnostic test at unit start-up verifies system performance

Application flexibility

- Capacity range from 9 to 540 lbs/hr for each unit
- Link up to 4 units together for capacities of up to 2160 lbs/hr
- Supports all types of water: tap, softened, reverse osmosis or deionized; easy to field-convert if water type changes

- Disperses steam through ductwork or directly into a space
- Stainless steel serpentine and copper helical-shaped heat exchangers provide a wide capacity range

Minimal maintenance

- Microprocessor accumulates unit run-time and displays recommended maintenance interval on keypad
- End-of-season autodrain eliminates microbial growth
- Water skimmer skims off floating minerals at user-adjustable intervals
- Timer-operated drain and flush removes precipitated minerals from evaporating chamber
- Constant thermal expansion and contraction of heat exchanger continuously sheds mineral buildup
- Cleanout plate and removable cover provide access for inspection and servicing

Microprocessor-based VAPOR-LOGIC₂ control

- Output programmable for on-off or modulating control
- Compatible with most building management systems; accepts all input signals
- Easy to use keypad interface displays current conditions and, in the unlikely event of an error, displays fault codes to reduce troubleshooting time
- Cold-snap offset option prevents window condensation
- VAV control option
- Freeze protection option

Guaranteed absorption

- Cataloged and guaranteed steam absorption distances
- Unique tubelets in dispersion tubes eliminate condensate drips
- Published absorption tables for sizing and selecting the correct dispersion option
- DRI-CALC[®] software available for computer calculation of absorption distances and dispersion unit selection

LTS system.

LTS[®] components.

1. Controller

The VAPOR-LOGIC₂[®] microprocessor controls all functions of the humidifier: when it runs, when it shuts off, when it fills, when it drains (see Page 6).

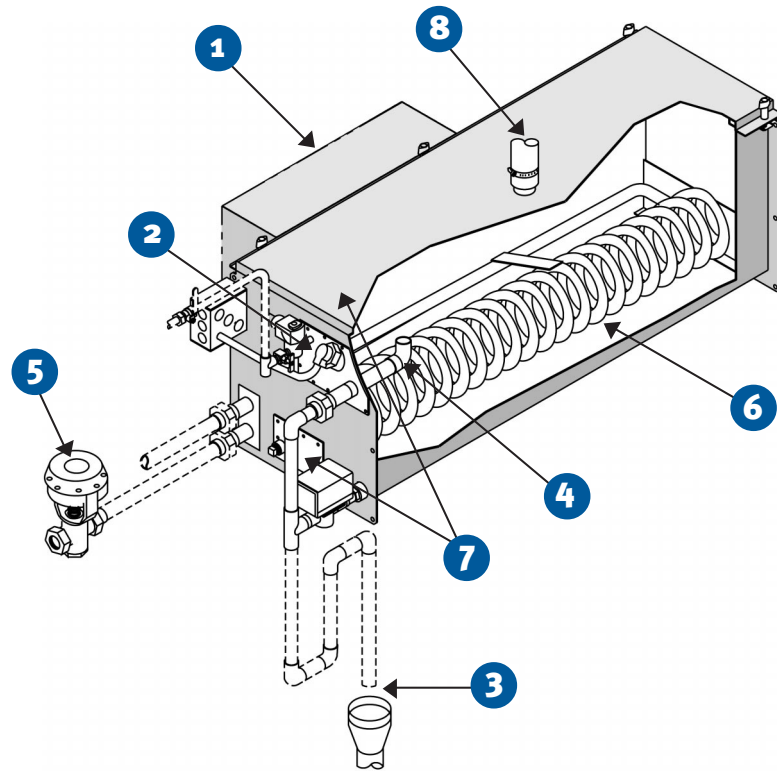

2. Water level probe

For use with softened or unsoftened water, the LTS has a three-level probe that is monitored by the controller. For DI/RO water, a stainless steel float valve system monitors and controls water level.

3. Drain

Duration and frequency of drain can be adjusted through keypad. The controller automates the end-of-season drain function by draining the evaporating chamber, after 72 hours without a call for humidity, to avoid possible stagnant water and microbial growth. (72 hours for tap/softened, 7.2 hours for DI/RO.) The unit will automatically refill and resume operation upon a call for humidity.

4. Water skimmer

The water skimmer reduces surface minerals in the evaporating chamber. The skim cycle is activated by the controller and adjusted with the keypad.

5. Modulating control valve

Upon a call for humidity, the controller opens the modulating valve allowing the hot liquid to enter the heat exchanger from an existing hot liquid loop.

6. Heat exchanger

The heat exchanger transfers energy from the hot liquid to the makeup water to generate steam.

7. Service access

Access cover and cleanout plate allow for periodic inspection and servicing of the evaporating chamber.

8. Steam outlet

Steam generated from the unit rises and exits through the steam outlet and travels to the dispersion unit through either a vapor hose or a hard pipe connection.

1. Create steam.

LTS[®] principle of operation.

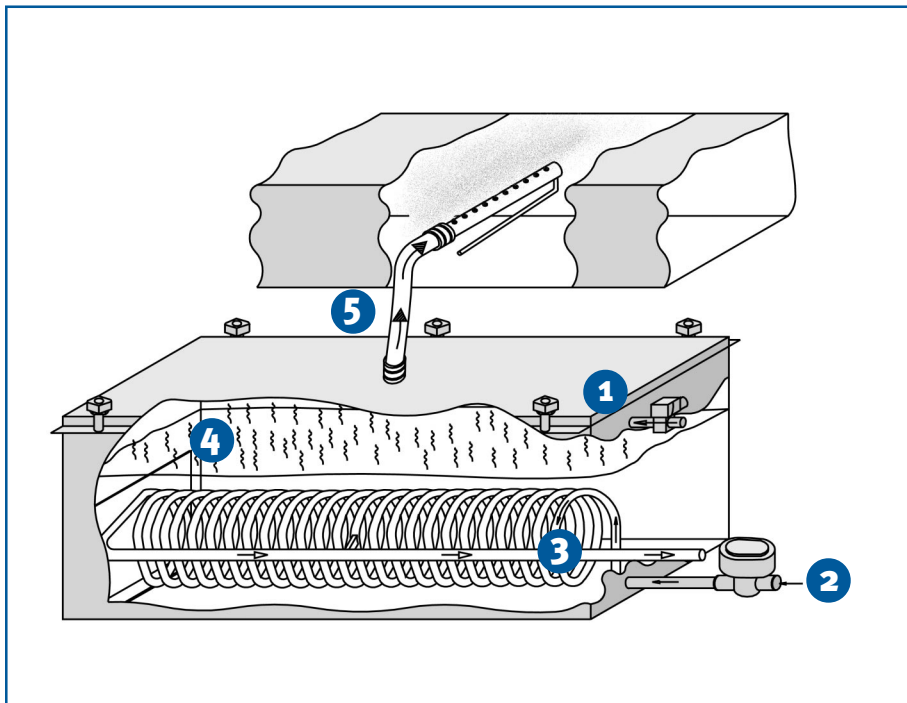

1. When the system is first activated, the water makeup valve opens, and the evaporating chamber fills to the operating level.
2. On a call for humidity, hot liquid passes through the modulating control valve to the heat exchanger, causing the water in the evaporating chamber to boil. The water makeup valve opens and closes as needed to maintain the operating level.
3. Hot liquid in the heat exchanger returns to the hot liquid source (which, for hot water, would be a boiler).
4. During refill, a portion of the surface water is skimmed off and drained, carrying away precipitated minerals.
5. Steam created in the evaporating chamber flows through the steam hose or piping into the dispersion assembly, where it is discharged into the airstream.

1. Create steam.

Control with VAPOR-LOGIC₂[®]

VAPOR-LOGIC₂ microprocessor control

The VAPOR-LOGIC₂ microprocessor is programmed to control water level, skim and drain functions, and heating element operation. The display shows system diagnostics, fault indications, and readouts of current conditions such as relative humidity and output in pounds per hour. The keypad is used to program desired operating functions of the computer.

Summary of features

- **End-of-season automatic drain**
- **Automatic drain/flush system**
- **Surface skimmer**
Surface water bleed-off is adjusted by user with the keypad.
- **Multiple signal compatibility**
Accepts mA, ohms and VDC signals.
- **Key pad displays:**
 - System output in lbs/hr
 - Space or room RH %
 - User-adjustable operating interval between drain and flush cycles
 - Duration of drain and flush cycles
 - Operating hours remaining before next recommended servicing
 - Maintenance requirements display
 - Control options (on-off or steam modulating)
 - Optional features (VAV control, cold-snap offset)
 - Upper line review
Any function may be set to appear on the upper line readout to more closely monitor that function.
 - System fault indicator
In the unlikely event of an error, keypad displays fault codes to reduce troubleshooting time.

Control options

- **On-off control**
RH control to $\pm 5\%$.
Typically used for applications having slow-changing conditions and small loads, such as human comfort applications with a capacity under 50 lbs/hr.
- **Time proportioning (TP) modulation**
A contactor stage is cycled on and off for varying portions of 20-second time periods to achieve modulated output of the humidifier.

2. Control.

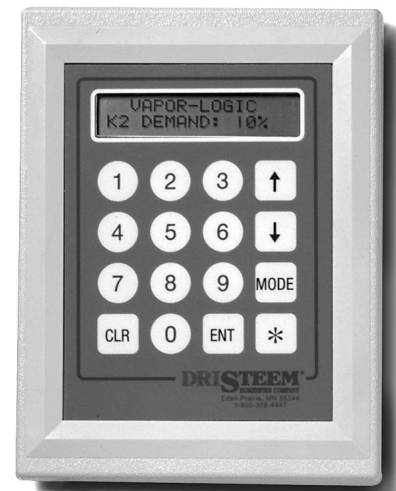

The VAPOR-LOGIC display and keypad allows the user to review and adjust functions of the humidifier.

Drip-free dispersion basics.

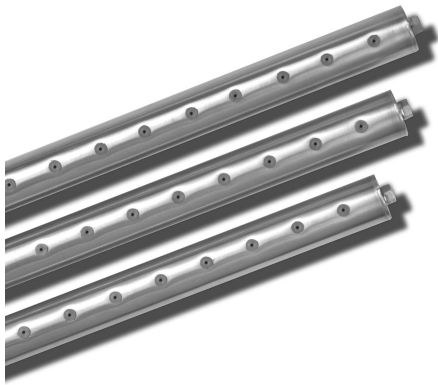

DRI-STEEM's dispersion tubes are fitted with one or two rows of closely-spaced thermal-resin tubelets to evenly disperse steam across the airstream.

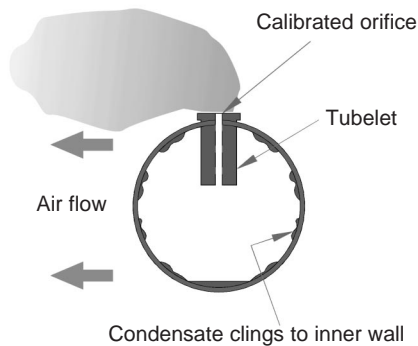

DRI-STEEM's unique tubelets extend into the center of the tube so only the hottest, driest steam is discharged into the air.

Guaranteed absorption distances

Using data collected in our on-site test lab, we have developed guaranteed steam absorption distances. Performance charts allow you to choose equipment that will accommodate any application (shown on Pages 14-18).

Dry steam

Adding humidification to an airstream without creating wetness in the duct system is critical to maintain a healthy environment. Wet areas in ducts are a threat to the health of building occupants since they moisten the dust on the duct floor, creating ideal breeding grounds for disease-producing microbes. In addition, water accumulating in ducts can drip and cause damage to a building.

Steam escapes drip-free through tubelets

All LTS[®] dispersion tube units discharge steam through thermal-resin tubelets fitted into dispersion tubes. These tubelets extend from the center of the tube, where the steam is driest, through the tube wall, to the duct airstream. In essence, the tubelets provide a temperature-neutral escape tunnel for the steam, allowing the steam to cross over lower-temperature metal without condensing or dripping. Each tubelet contains a calibrated orifice sized for duct air velocity and steam capacity. These tubelets are a DRI-STEEM exclusive, and are essential for drip-free steam dispersion.

Condensate drains away

Some condensation is inevitable in steam dispersion, but through careful design, condensate can be controlled and directed away from where it can cause problems. For example, the

ULTRA-SORB[®] dispersion unit has a unique double-header design that uses gravity to remove condensate. Steam enters the top header, escapes through the tubelets, and condensate drains out the bottom header. In the RAPID-SORB[®] dispersion unit, steam enters through the single bottom header with pressures carefully managed so that condensate is not pushed out along with the steam, but rather drains down through the same bottom header.

For more information about dispersion units, see Pages 12-18.

3. Disperse.

LTS[®] dimensions.

LTS and LTS-DI, sizes 25 and 100 (single heat exchanger)

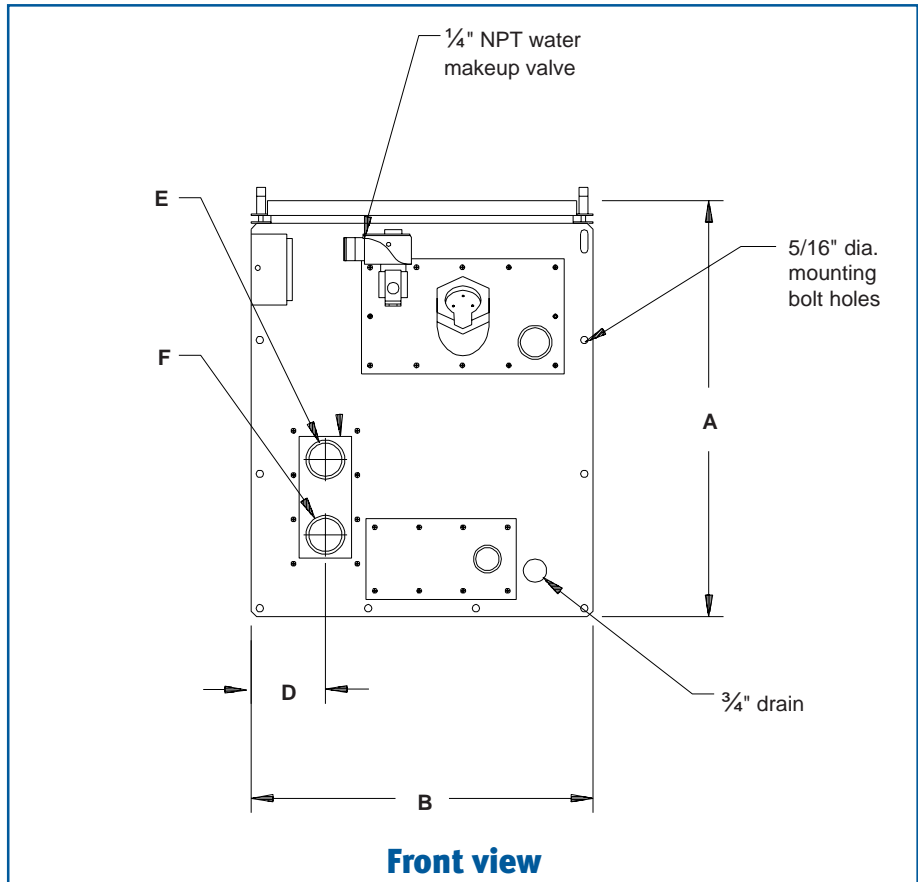
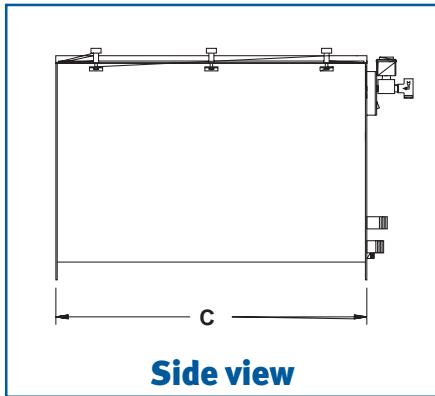

Dimensions.

Table 8-1: Mechanical dimensions

Model	Description	LTS-25C*		LTS-25S**		LTS-100C*		LTS-100S**	
		in.	mm	in.	mm	in.	mm	in.	mm
A	Overall height	18.13	460	18.13	460	18.13	460	18.13	460
B	Face width	14.75	375	14.75	375	19.25	490	19.25	490
C	Face length	23.50	600	23.50	600	39.50	1005	39.50	1005
D	Distance to heat exchanger	3.20	80	3.20	80	3.20	80	3.20	80
E	Return outlet	1.00	25	.75	20	1.00	25	1.00	25
F	Supply inlet	1.00	25	.75	20	1.00	25	1.00	25

Table note:

* C=copper

** S=stainless steel

LTS[®] dimensions.

LTS and LTS-DI 200S and 400C (dual heat exchangers)

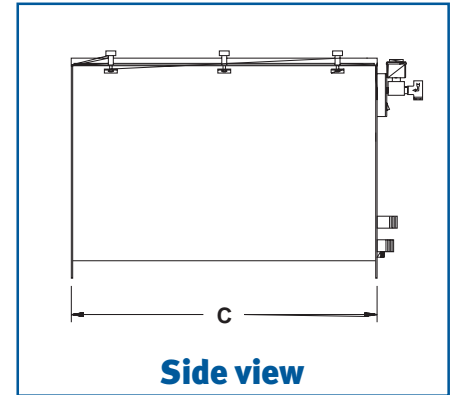
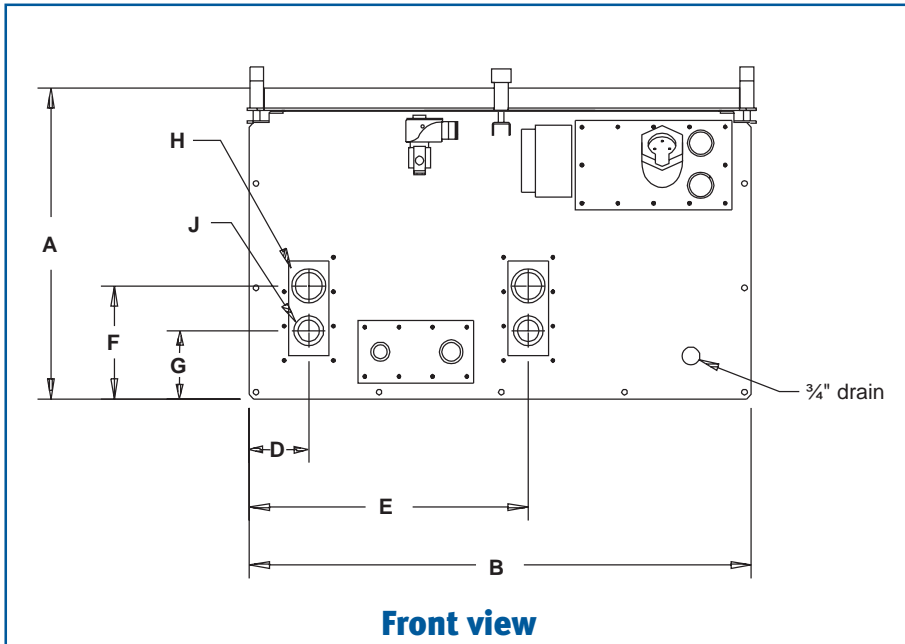

Table 9-1: Mechanical dimensions

Model	Description	LTS-200S**		LTS-400C*	
		inches	mm	inches	mm
A	Overall height	18.13	460	18.13	460
B	Face width	28.25	720	28.25	720
C	Face length	55.00	1400	55.00	1400
D	Distance to first heat exchanger	3.20	80	3.20	80
E	Distance to second heat exchanger	15.50	395	15.50	395
F	Distance from bottom to return outlet	6.67	170	6.67	170
G	Distance from bottom to supply inlet	3.67	95	3.67	95
H	Return outlet	1.00	25	1.00	25
J	Supply inlet	1.00	25	1.00	25

Table note:

* C=copper

** S=stainless steel

Dimensions.

LTS[®] capacities.

Table 10-1: Capacity of LTS models

			Output (lbs/hr and kg/h)								Pressure drop through heat exchanger	
Model	Flow		Hot water supply temperature									
			240°F	116°C	250°F	121°C	260°F	127°C	280°F	138°C		
	GPM	l/mn	lbs/hr	kg/h	lbs/hr	kg/h	lbs/hr	kg/h	lbs/hr	kg/h	psi	kPa
LTS-25C	8	30	25	11	45	20	65	29	100	45	1.0	10
	12	45	40	18	60	27	85	39	135	61	1.5	14
	15	57	50	23	75	34	105	48	160	73	2.0	17
	17	64	60	27	90	41	120	54	170	77	2.5	21
LTS-25S	4	15	9	4	13	6	17	8	21	10	3.0	21
	6	23	11	5	15	7	19	9	23	10	5.5	41
	7.5	28	12.5	6	16.5	7	21	10	25	11	8.0	55
LTS-100C	12	45	70	32	90	41	120	54	195	88	3.0	28
	15	57	85	39	110	50	140	64	230	104	5.0	41
	17	64	95	43	125	57	155	70	250	113	6.5	55
LTS-100S	7.5	28	33	15	40	18	48	22	59	27	2.0	14
	10	38	38	17	47	21	56	25	69	31	3.0	21
	15	57	45	20	55	25	65	29	80	36	6.0	41
*LTS-200S	15	57	60	27	75	34	105	48	135	61	2.5	21
	20	76	80	36	110	50	145	66	180	82	4.0	28
	30	114	90	41	125	57	165	75	205	93	7.0	48
*LTS-400C	24	91	190	86	250	113	310	141	470	213	4.0	28
	30	114	240	109	300	136	350	159	510	231	6.0	41
	34	129	260	118	320	145	380	172	540	245	8.0	69

* 2 heat exchangers and 2 valves

Table notes:

- Use with supply water above 250°F (121°C) is not approved by ASME.
- Dimensions and specifications subject to change without notice.

Table 10-2: Medium and high temperature water heating systems

Properties of water 212° to 340°F (100° to 171°C)															
Temp.	°F	212	220	230	240	250	260	270	280	290	300	310	320	330	340
	°C	100	104	110	116	121	127	132	138	143	149	154	160	166	171
Pressure	psia	14.7	17.2	20.8	25.0	29.8	35.4	41.9	49.2	57.6	67.0	77.7	89.7	103.1	118.0
	kPa	101.3	118.4	143.2	172.0	205.5	244.1	288.4	339.0	396.6	461.7	535.2	617.8	710.1	813.1

Capacity.

LTS[®] connections.

LTS mounting options

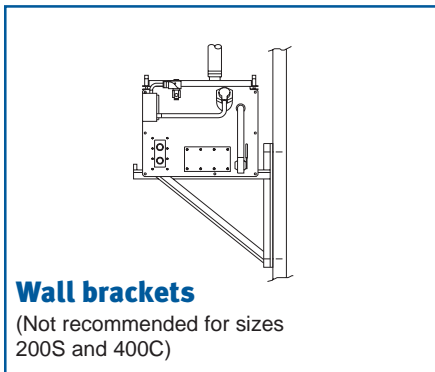
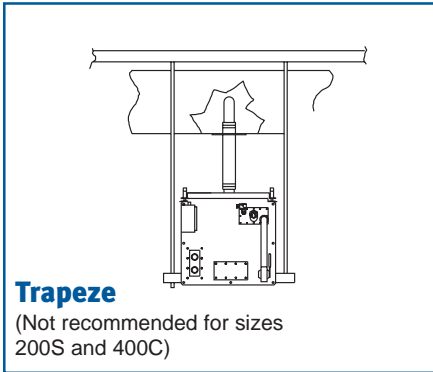
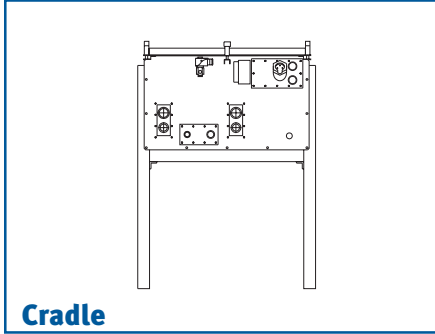
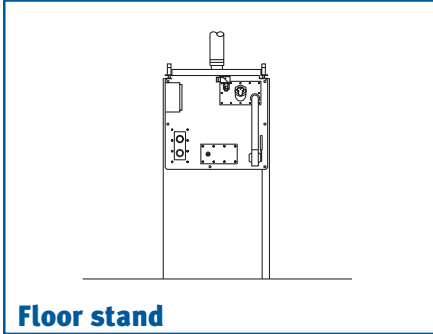

Steam supply piping

Vapor hose, rigid tubing, or steel pipe connects the LTS to the dispersion assembly, and can be ordered with fittings.

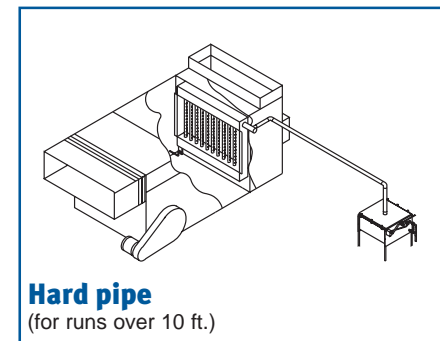
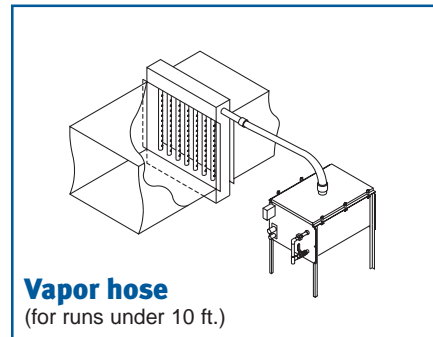
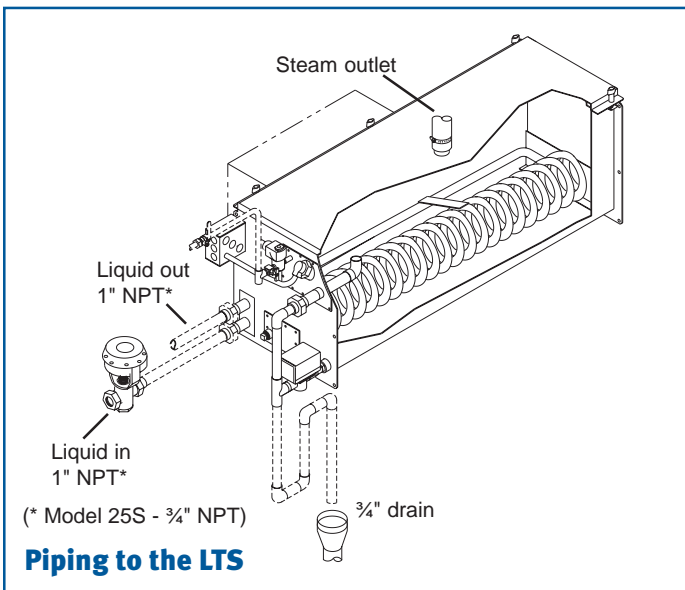

Mounting/piping

LTS[®] steam dispersion options.

Dispersion options.

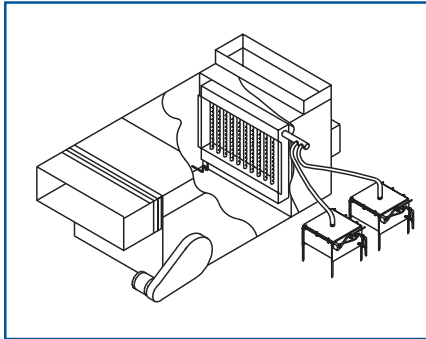

ULTRA-SORB[®]

The multiple tube ULTRA-SORB allows virtually instantaneous steam absorption. The unit can be installed within inches upstream of dampers, coils, or elbows without dripping.

The ULTRA-SORB's steam downflow design allows for high capacity dispersion. The unit is assembled at the factory within a mounting frame, and installs easily.

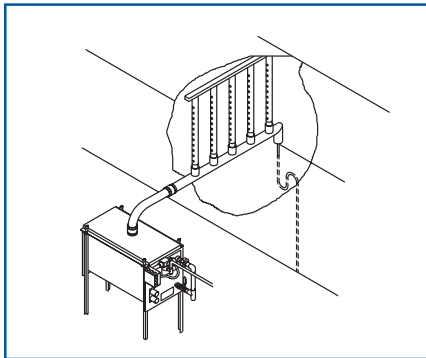

RAPID-SORB[®]

The RAPID-SORB has a single header design with steam flowing up from a bottom header. This design is an excellent choice for medium capacity systems where multiple tubes are needed to handle the load and/or when nonwetting absorption distance is limited. RAPID-SORBs are assembled on-site.

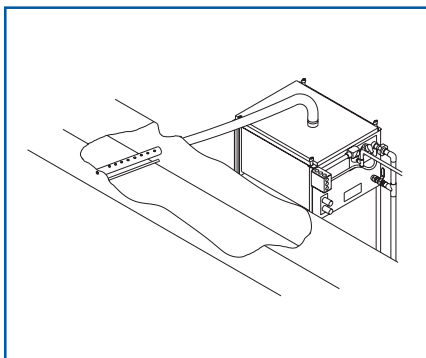

Single-Tube

The Single-Tube hose and duct-tube system is an excellent choice for lower capacity applications and where there is room for a longer absorption distance.

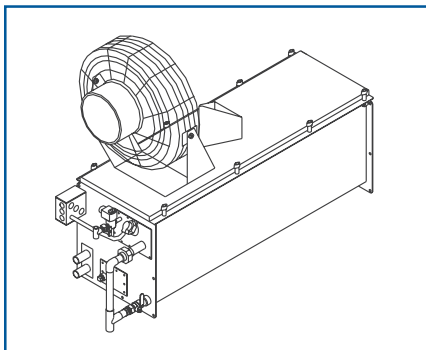

AREA-TYPE

The AREA-TYPE dispersion unit uses a fan to disperse steam in large open spaces. It is particularly useful where there are no air-handling ducts. The fan distributes steam quietly and efficiently, without introducing water droplets into the air.

Determining steam absorption.

Absorption distances.

Sample exercise

DRI-STEEM offers four dispersion options for the LTS® (described on the opposite page). To learn more about how to specify a dispersion unit based on absorption distance, read the sample problem below. For purposes of this sample problem, assume you have chosen to use ULTRA-SORB® units because you want preassembled panels.

Assume the entering air is 20% RH, and the leaving air needs to be 70% RH. Design for a nonwetting distance of 24 inches maximum.

Solution

Refer to Table 14-1: ULTRA-SORB absorption/nonwetting distances on Page 14. Find 20% entering RH. Proceed vertically until you intersect the 70% leaving RH line. Draw a line horizontally from that point to the right to see that for 24" of nonwetting distance, 6" tube spacing would be the closest match.

Verify capacity

From Table 14-2: ULTRA-SORB steam flow capacities on Page 14, see that for 6" spacing, maximum capacity is 18 lbs/sq. ft./ hr. Multiply this value by the active face area of the ULTRA-SORB to determine if the unit will produce adequate output capacity. If the capacity is inadequate, go to the next smaller tube spacing.

Steam absorption considerations

1. Absorption, or nonwetting distance, is the dimension downstream from the leaving side of the steam dispersion assembly to the point where wetting will not occur, although wisps of steam may be present. Solid objects at duct air temperature, such as coils, dampers, fans, etc., downstream of this dimension will remain dry.
2. Note that the rise in RH (the difference between entering and leaving RH) has a direct bearing on the absorption distance. As the rise increases, more humidity needs to be dispersed into the air, and thus the absorption distance increases.
3. CAUTION: When installing upstream of high efficiency filters, visible condensed steam wisps entering the filter bank can result in a wetted filter. If you need to install upstream of high efficiency filters, consult your rep or DRI-STEEM directly for special recommendations.
4. Uneven air flow over the cross-section of an ULTRA-SORB may result in nonuniform mixing of steam with air which, in turn, will adversely affect the absorption distance.

Notes:

- Final equipment selection should account for condensate loss.
- Dispersion assembly should accommodate maximum output capacity of humidifier.

ULTRA-SORB[®] dispersion unit.

ULTRA-SORB.

Table 14-1: ULTRA-SORB absorption/non-wetting distances

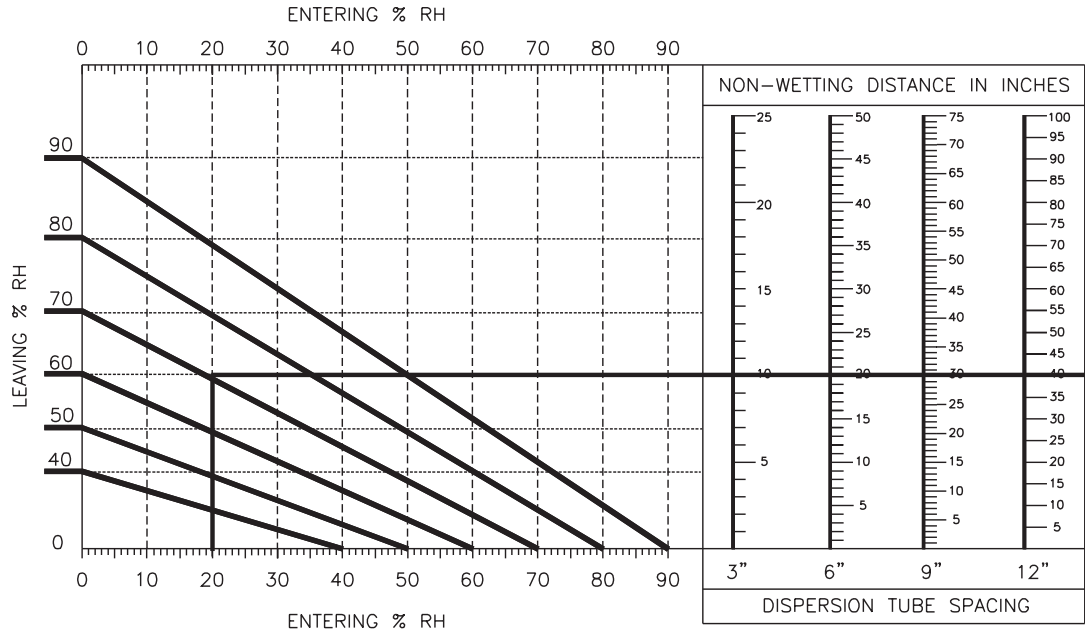

Note:

The above absorption data applies to all air velocities up to 2000 fpm (10 m/s), and is based on air leaving the zone of humidification at conditions of 55° (13°C) and the stated % RH.

Table 14-2: ULTRA-SORB steam flow capacities

Tube spacing (inches)	Maximum (lbs/sq.ft./hr)	Tube spacing (mm)	Maximum (kg/sq.m/hr)
3	36	75	175
6	18	150	88
9	12	225	59
12	9	300	44

Note:

The above steam flow capacity data is based on pounds (kg) of steam per hour per square foot (meter) of face area (exclusive of headers) at various tube spacings.

ULTRA-SORB® dispersion unit.

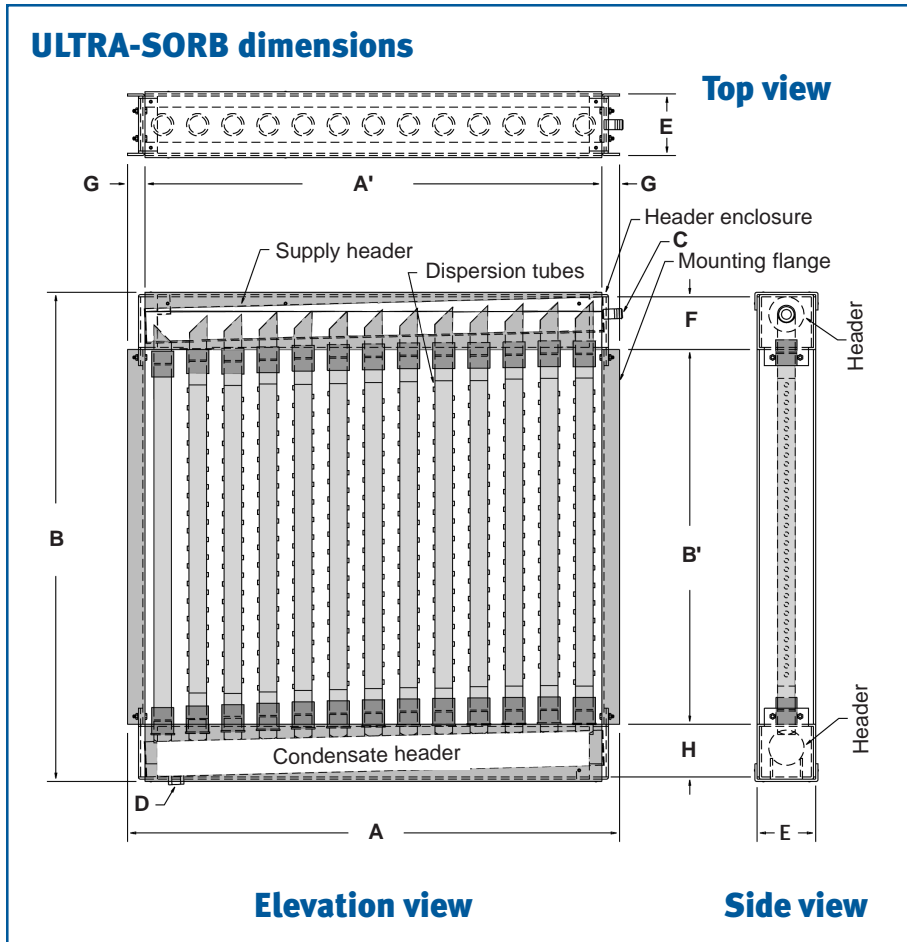

ULTRA-SORB.

Table 14-1: ULTRA-SORB dimensions

Dimension	Description	Inches (mm)
A	Overall width	15" (381) minimum to 120" (3048) maximum in 1" (25) increments
A'	Face width	12" (305) minimum to 120" (3048) maximum in 1" (25) increments
B	Overall height	21" (533) minimum to 129" (3277) maximum in 1" (25) increments
B'	Face height	12" (305) minimum to 120" (3048) maximum in 1" (25) increments
C	Steam inlet	Boiler steam: determined by supply steam pressure
D	Condensate drain (NPT)	¾"
E	Header enclosure (front to back)	3" and 4" header E=5", 5"header E=6" and 6" header E=7"
F	Header enclosure (top to bottom)	3" header F=4½", 4" header F=5½", 5" header F=6½", 6" header F=7½"
G	Flange	1½" (40)
H	Condensate header enclosure	4½" (115)

Notes:

- Header diameter varies with capacity.
- Dimensions and specifications subject to change without notice.

RAPID-SORB® dispersion unit.

RAPID-SORB.

Table 16-1: RAPID-SORB absorption/non-wetting distances

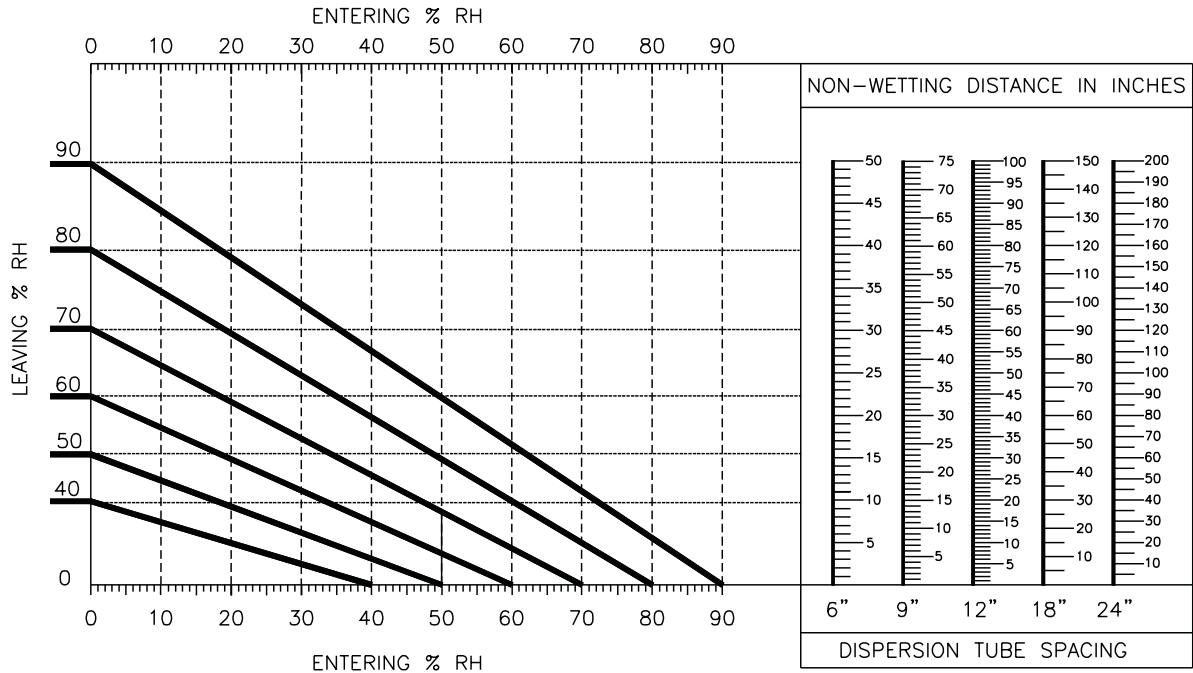

Note:

The above absorption data applies to all air velocities up to 2000 fpm (10 m/s), and is based on air leaving the zone of humidification at conditions of 55° (13°C) and the stated % RH.

Table 16-2: RAPID-SORB dispersion tube capacities

Tube capacity (lbs/hr)	Tube diameter	Tube capacity (kg/h)	Tube diameter
7 or less	1"	3 or Less	25 mm
8-35	1½"	4-16	40 mm
36-70	2"	17-32	50 mm

Table 16-3: RAPID-SORB header capacities

Header diameter	Capacity (lbs/hr)	Header diameter	Capacity (kg/h)
1½"	Up to 100	40 mm	Up to 45
2"	101-250	50 mm	46-113
3"	251-500	75 mm	114-227
4"	501-800	100 mm	228-363

RAPID-SORB dimensions

All RAPID-SORB units are custom sized and field assembled to fit the duct or air handler.

Single-Tube dispersion unit.

Table 17-1: Single-Tube absorption/non-wetting distances

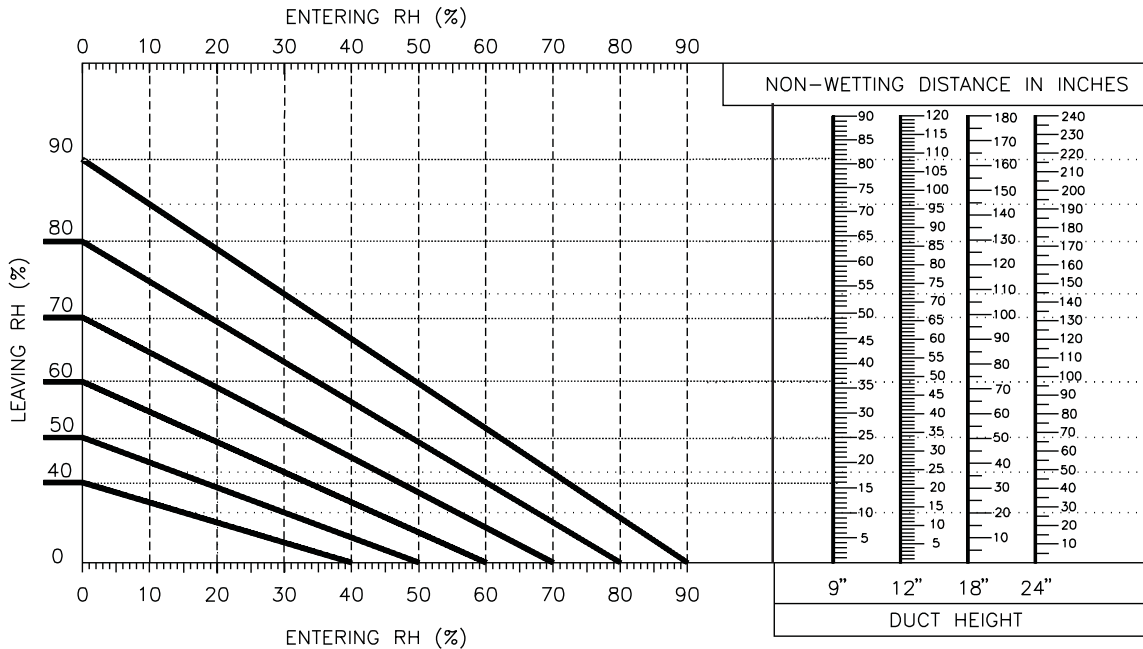

Figure 17-1: Pitch necessary for proper drainage of condensate

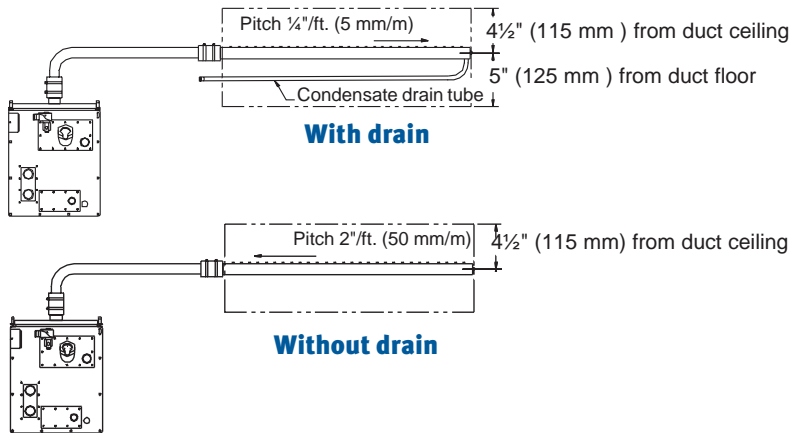

Table 17-2: Single-Tube hose and duct tube capacities

Tube Diameter		Capacity (lbs/hr)			
		Without drain		With drain	
inches	mm	(lbs/hr)	(kg/h)	(lbs/hr)	(kg/h)
1"	25	10	5	NA	NA
1 1/2"	40	28	13	57	26
2"	50	57	26	85	39

Single-Tube.

AREA-TYPE dispersion unit.

Table 18-1: AREA-TYPE minimum distances for rise, spread and throw

Space temp.	Space RH		50 PPH	20 kg/h	100 PPH	45 kg/h	150 PPH	65 kg/h	200 PPH	90 kg/h	250 PPH	110 kg/h	285 PPH	130 kg/h
60° F 16° C	30%	Rise	1 ft.	0.5 m	4 ft.	1.5 m	6 ft.	2.0 m	7 ft.	2.5 m	8 ft.	2.5 m	9 ft.	3.0 m
		Spread	2 ft.	1.0 m	4 ft.	1.5 m	5 ft.	2.0 m	7 ft.	2.5 m	8 ft.	2.5 m	9 ft.	3.0 m
		Throw	6 ft.	2.0 m	10 ft.	3.0 m	12 ft.	4.0 m	13 ft.	4.0 m	15 ft.	5.0 m	17 ft.	5.5 m
	40%	Rise	1 ft.	0.5 m	4 ft.	1.5 m	6 ft.	2.0 m	8 ft.	2.5 m	9 ft.	3.0 m	10 ft.	3.0 m
		Spread	2 ft.	1.0 m	4 ft.	1.5 m	5 ft.	2.0 m	7 ft.	2.5 m	9 ft.	3.0 m	10 ft.	3.0 m
		Throw	6 ft.	2.0 m	10 ft.	3.0 m	12 ft.	4.0 m	14 ft.	4.5 m	16 ft.	5.0 m	18 ft.	5.5 m
	50%	Rise	1 ft.	0.5 m	4 ft.	1.5 m	6 ft.	2.0 m	8 ft.	2.5 m	9 ft.	3.0 m	10 ft.	3.0 m
		Spread	2.5 ft.	1.0 m	5 ft.	2.0 m	5 ft.	2.0 m	7 ft.	2.5 m	9 ft.	3.0 m	10 ft.	3.0 m
		Throw	6 ft.	2.0 m	10 ft.	3.0 m	12 ft.	4.0 m	14 ft.	4.5 m	16 ft.	5.0 m	18 ft.	5.5 m
70° F 21° C	30%	Rise	1 ft.	0.5 m	3 ft.	1.0 m	4 ft.	1.5 m	5 ft.	2.0 m	5 ft.	2.0 m	7 ft.	2.5 m
		Spread	1.5 ft.	0.5 m	3 ft.	1.0 m	4 ft.	1.5 m	5 ft.	2.0 m	5 ft.	2.0 m	7 ft.	2.5 m
		Throw	4 ft.	1.5 m	8 ft.	2.5 m	10 ft.	3.0 m	11 ft.	3.5 m	12 ft.	4.0 m	14 ft.	4.5 m
	40%	Rise	1 ft.	0.5 m	3 ft.	1.0 m	4 ft.	1.5 m	5 ft.	2.0 m	6 ft.	2.0 m	7 ft.	2.5 m
		Spread	2 ft.	1.0 m	3 ft.	1.0 m	4 ft.	1.5 m	5 ft.	2.0 m	6 ft.	2.0 m	7 ft.	2.5 m
		Throw	4 ft.	1.5 m	8 ft.	2.5 m	11 ft.	3.5 m	12 ft.	4.0 m	13 ft.	4.0 m	15 ft.	5.0 m
	50%	Rise	1 ft.	0.5 m	3 ft.	1.0 m	4 ft.	1.5 m	5 ft.	2.0 m	5 ft.	2.0 m	7 ft.	2.5 m
		Spread	2 ft.	1.0 m	3 ft.	1.0 m	4 ft.	1.5 m	5 ft.	2.0 m	5 ft.	2.0 m	7 ft.	2.5 m
		Throw	4 ft.	1.5 m	8 ft.	2.5 m	11 ft.	3.5 m	12 ft.	4.0 m	14 ft.	4.5 m	16 ft.	5.0 m

AREA-TYPE.

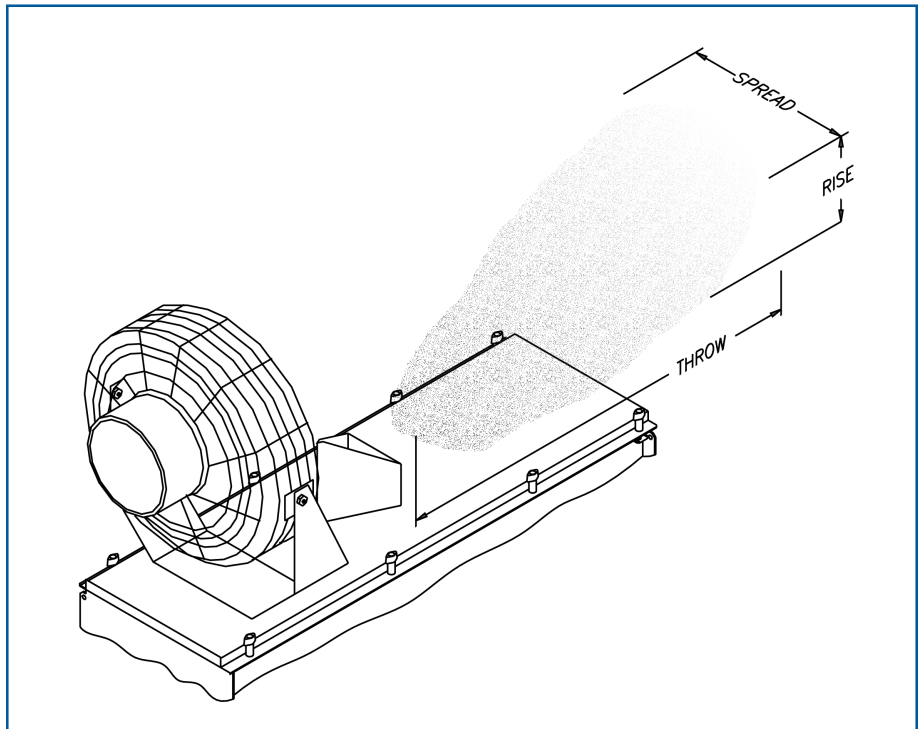

Write the Specs.

Liquid-to-steam humidifier

- A. The humidifier shall be UL/CUL listed and CE approved.
- B. Tank and cover shall be 14-gauge stainless steel with Heli-arc welded seams.
- C. Heat exchanger shall be nickel-coated tubular copper or TEFLON-coated tubular stainless steel.
- D. The liquid-to-steam humidifier shall be capable of supporting tap, softened or DI/RO makeup water.
- E. The humidifier shall contain the following operational and maintenance features:
 - 1. Water makeup valve control
 - 2. Auto/drain flush
 - 3. End-of-season drain
 - 4. Low water cutoff
 - 5. Modulating steam control
 - 6. Surface skimmer
 - 7. Removable cover
 - 8. Removable cleanout plate
- F. A microprocessor-based controller shall be provided and be capable of on/off, or modulating output control of humidifier as well as control of all fill and drain functions.
- G. A keypad shall be provided to serve as the human interface to the controller. The keypad shall be capable of monitoring and/or controlling the following parameters:

- 1. Relative humidity (RH) set-point and actual conditions in the space (from humidistat or humidity transmitter)
 - 2. Relative humidity (RH) set-point and actual conditions in the duct for variable air volume applications
 - 3. Relative humidity (RH) high limit set-point and actual conditions
 - 4. Total system demand in % of total humidifier capacity
 - 5. Total system output in lbs/hr
 - 6. Auto drain/flush frequency interval and duration
 - 7. End-of-season drain status
 - 8. System fault indicator
 - 9. High limit and air flow proving circuit condition
 - 10. Throttling range adjustment
 - 11. Time until service message
- H. The unit shall be supplied with a stainless steel dispersion assembly complete with calibrated orifice tubelets. Provide assembly for connection between liquid-to-steam humidifier and dispersion tube assembly.

- I. Accessories
 - 1. Aquastat shall sense and maintain the water temperature above freezing
 - 2. Vane or static pressure type air flow proving switch
 - 3. Duct high limit humidistat
 - 4. NEMA-4 control cabinet
 - 5. Factory mounting of the control cabinet on the humidifier
- J. The Liquid-to-Steam humidifier shall be supported with a warranty that ensures the product will be free from defects in materials and workmanship for a period of three years after installation or 27 months from shipment.

Typ. spec.

Expert help makes it easy.



DRI-CALC® computer software can help you size and select the right DRI-STEEM product for your particular application.

Ask a rep

Many years of hands-on experience have made DRI-STEEM sales representatives humidification experts. Supported by a strong force of DRI-STEEM application specialists, they are available to assist with any humidification need.

Read our Humidification Handbook

Read this handbook for everything you've ever wanted to know about humidification. It contains over 150 pages of technical information written in a very readable style. The handbook covers process requirements, RH control suggestions, design of systems, load sizing, use of the psychrometric chart, various humidifier types, and installation recommendations.

See the video

Ask your rep for our short video describing humidification essentials, indoor air quality (IAQ) issues, and DRI-STEEM's humidification systems.

Or let your computer figure it out

DRI-STEEM's exclusive software, DRI-CALC® is a user-friendly software program designed to save the engineer's time. The software sizes loads, selects equipment, writes specifications, and creates equipment schedules for DRI-STEEM products. It also includes drawings of products and an encyclopedia of humidification terms.

DRI-STEEM®
HUMIDIFIER COMPANY



14949 Technology Drive • Eden Prairie, MN 55344
Phone: (800) 328-4447 • (612) 949-2415 • Fax: (612) 949-2933
E-Mail: sales@dristeem.com • Web: www.dristeem.com

International office:

Bell Place, Bell Lane • Syresham, Brackley • NN13 5HP, U.K.
Phone: +44 1280 850122
Fax: +44 1280 850124
E-Mail: 106277.1443@compuserve.com

Continuous product improvement is a policy of DRI-STEEM Humidifier Company. Therefore, product features and specifications are subject to change without notice.

DRI-STEEM, LTS, RAPID-SORB, ULTRA-SORB, VAPOR-LOGIC, VAPOR-LOGIC₂ and DRI-CALC, are Registered Trademarks of the DRI-STEEM Humidifier Company.



Your DRI-STEEM representative is: